

Northern Contours

Lower Cabinet Assembly Instructions



MATERIALS NEEDED FOR COMPLETE ASSEMBLY:

- WOOD GLUE (type PVA)
- FINISH NAIL GUN
- SOFT RUBBER Mallet
- 1"- 1 ¼" NAILS FOR CABINET BOX AND FACE FRAME

CAUTION: DO NOT FORCE COMPONENTS INTO PLACE. Use rubber mallet for tapping components into dado grooves.

INVENTORY LIST:

- A - RIGHT SIDE PANEL
- B - LEFT SIDE PANEL
- C - BACK PANEL
- D - REAR STRETCHER
- E - FRONT STRETCHER
- F - NAILER
- G - TOE KICK
- H - FACE FRAME (ASSEMBLED)
- I - BOTTOM PANEL
- J - DRAWER SLIDE LEFT
- K - DRAWER SLIDE RIGHT

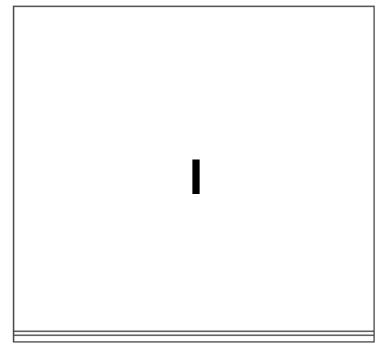
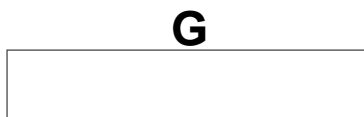
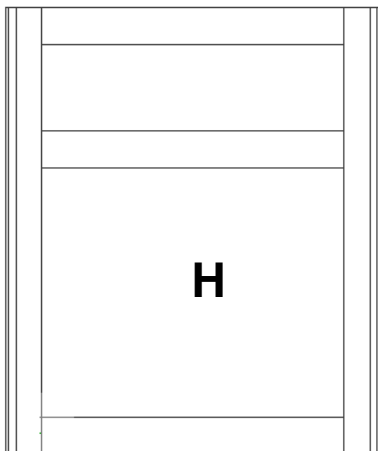
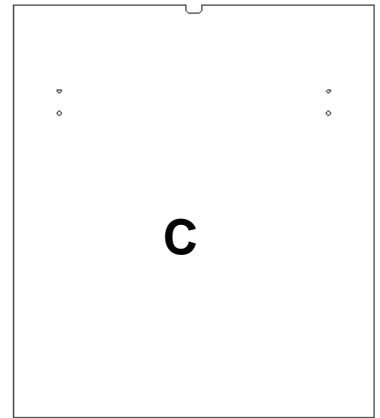
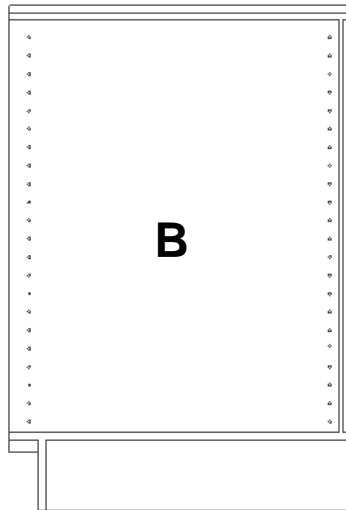
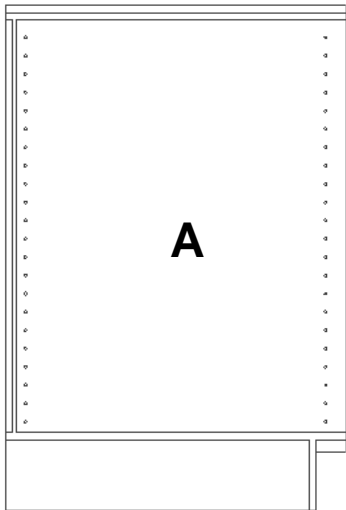

For ease of assembly, Mark all nail locations on outside of Place panels. Place left or right side panel on flat work surface. Apply an 1/8" continuous bead of glue to lower dado groove.

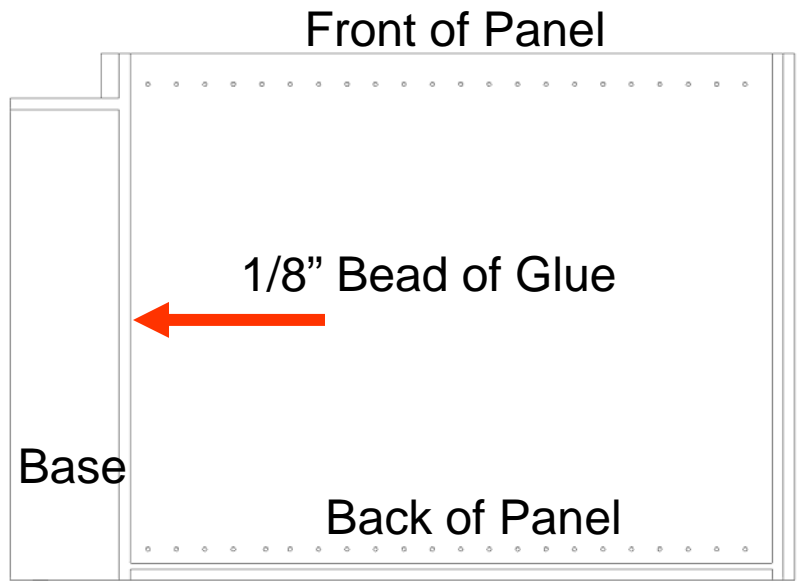

Apply 1/8" bead of glue to lower dado grooves. Insert base panel into left side panel dado, and secure with 1" nails on outside of face panel.

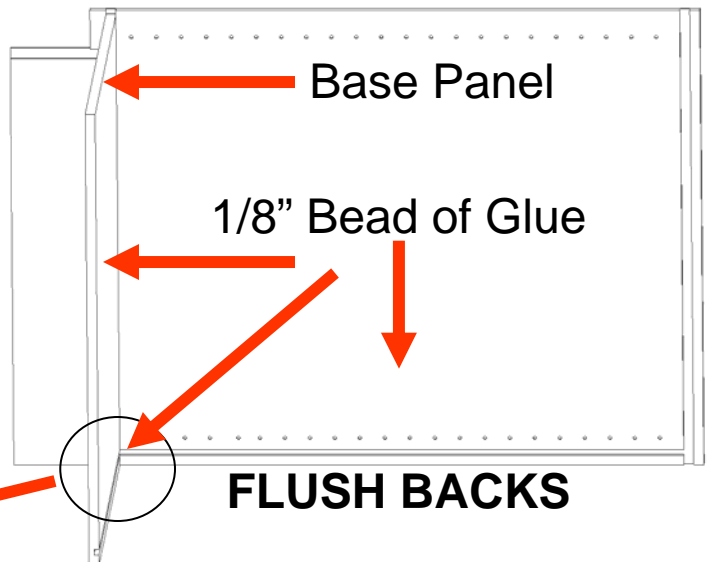

Slide Back Panel into dado position, with finished side facing in. Back Panel notch is for orientation, notch needs to face TOP of box, for drawer slide alignment.

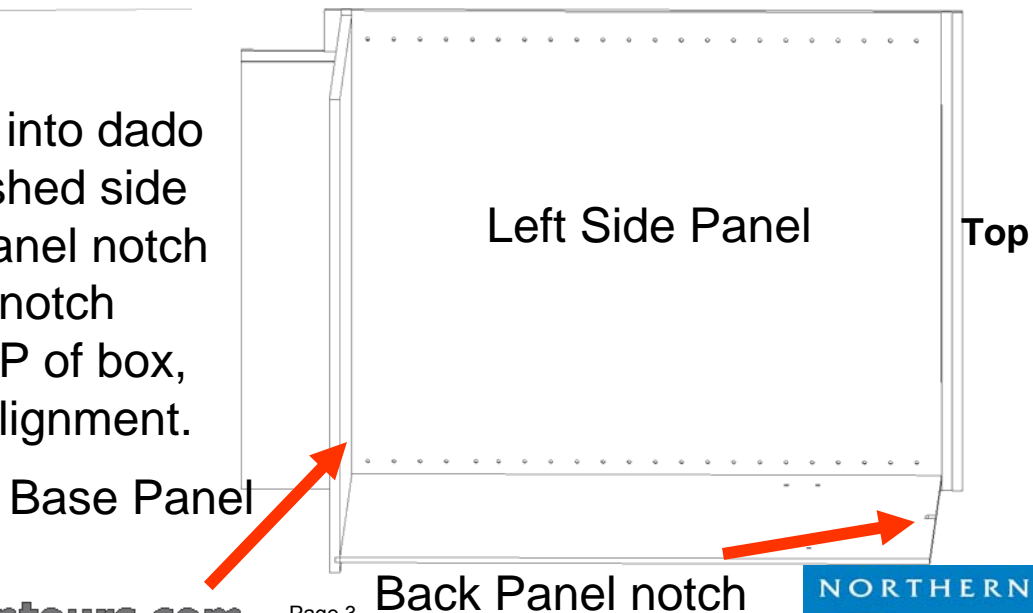

Apply 1/8" continuous Bead of Glue to stretcher dado and left side of stretcher, position rear stretcher in place and nail.

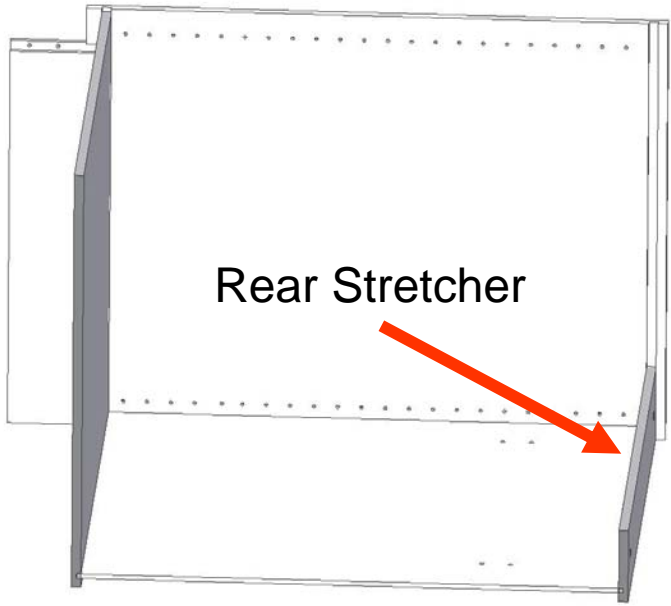
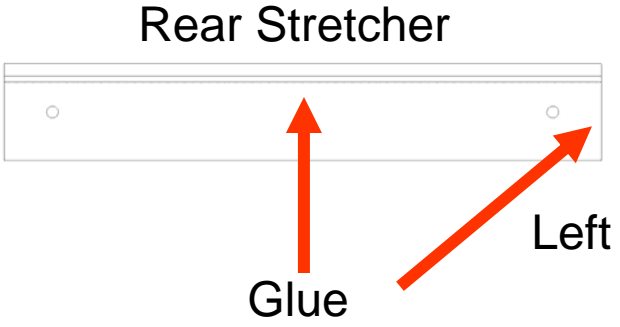

Apply 1/8" continuous Bead of Glue to right side panel dados.

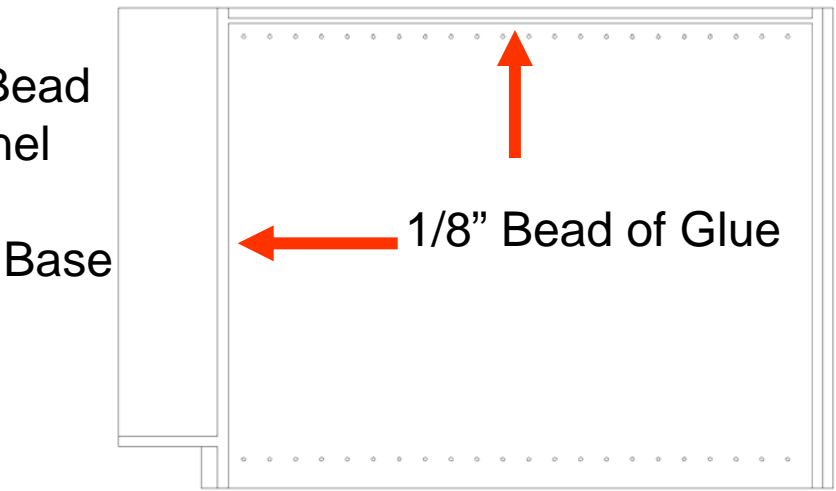

Apply 1/8" of Glue to Right side of Rear Stretcher.

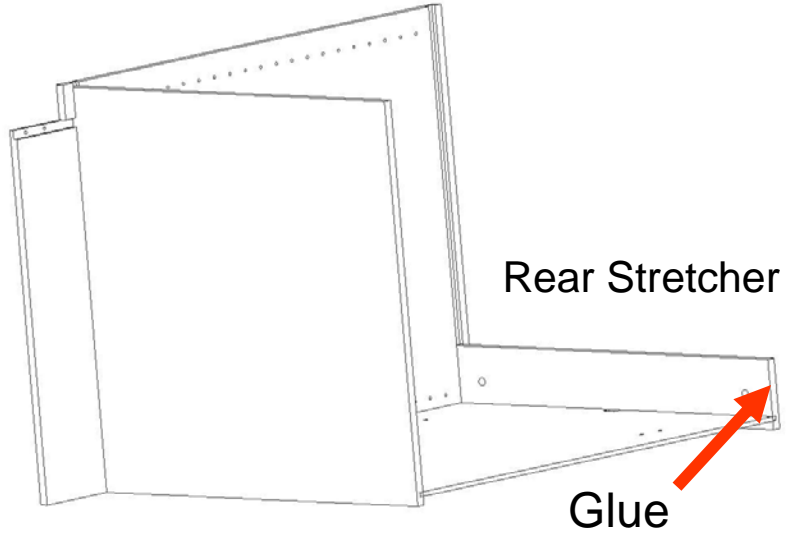

Assemble Right Side panel, aligning dado grooves into position. Secure Box by inserting nails into outer panel.

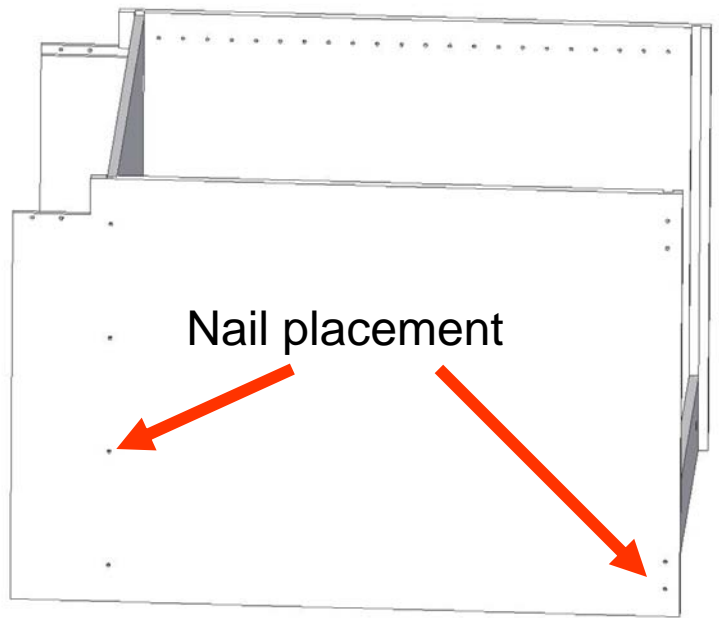

Slide Front Stretcher into dado grooves, final positioning is done once Face Frame is attached.

Place 1/8" continuous Bead of Glue on Toe Kick dadoes, insert Toe Kick and secure with 1" nails on both sides of panels.

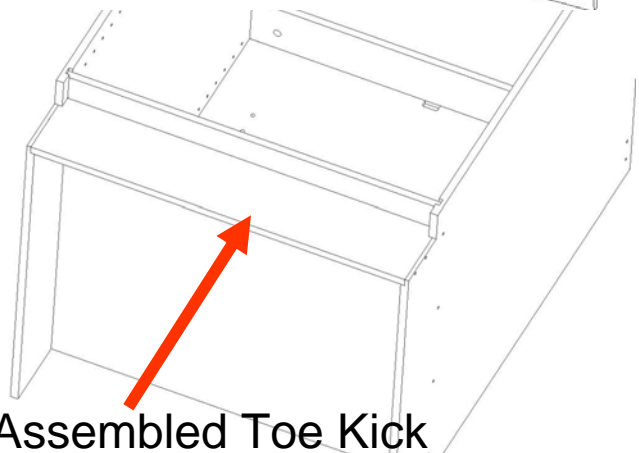
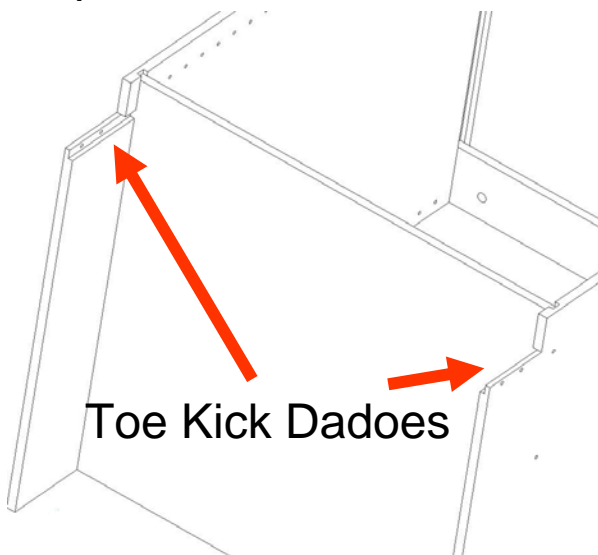
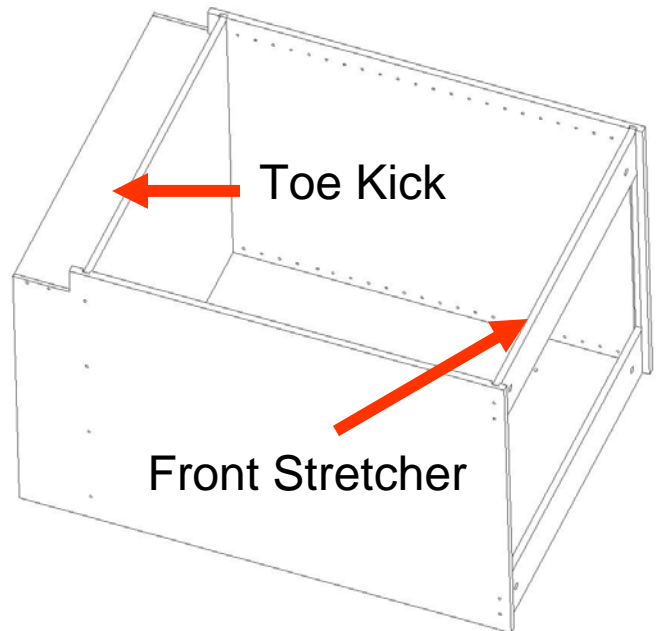

Dry fit face frame onto cabinet, if needed, sand corners of cabinet box to facilitate assembly.

Place 1/8" continuous Bead of Glue on Frame Frame dadoes.

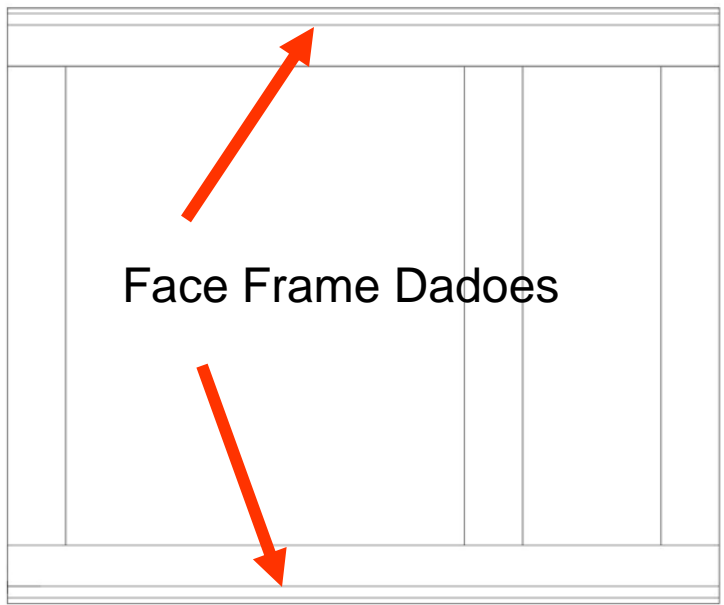

Apply 1/8" continuous Bead of Glue to front of base panel and stretcher prior to placing face frame on box. Align face frame rail to cabinet box sides, lightly tap with rubber mallet to assure face frame and cabinet box are joined. Nail on sides and horizontal rails.

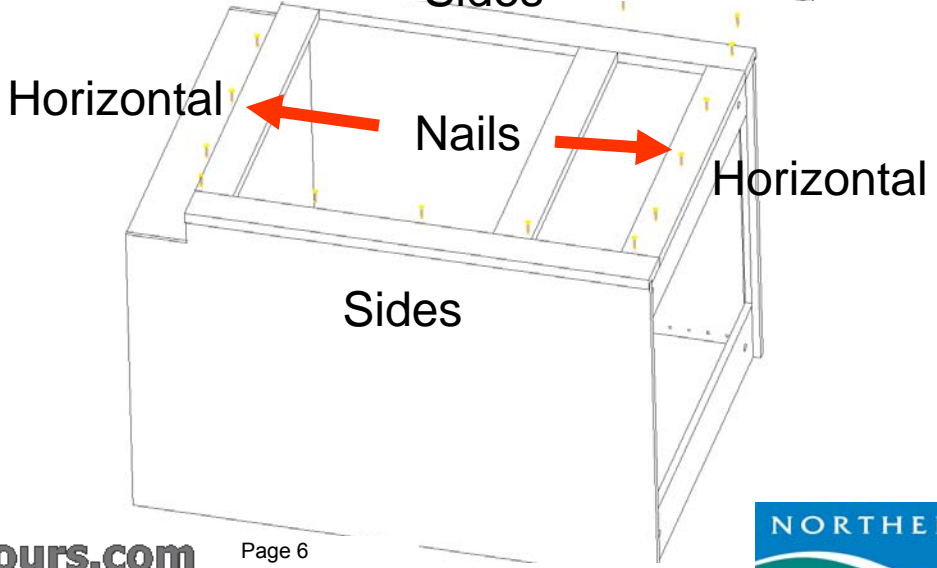
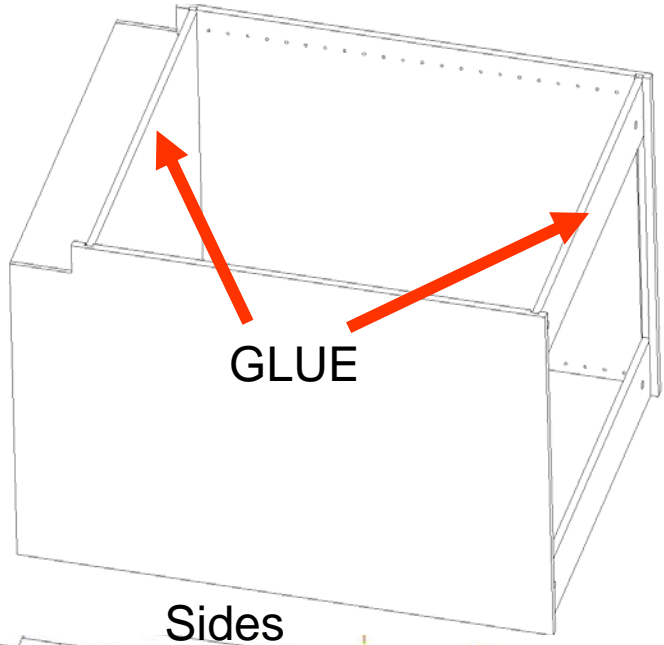

Position nailer onto back of cabinet box and secure with 1"- 1 ¼" nails.

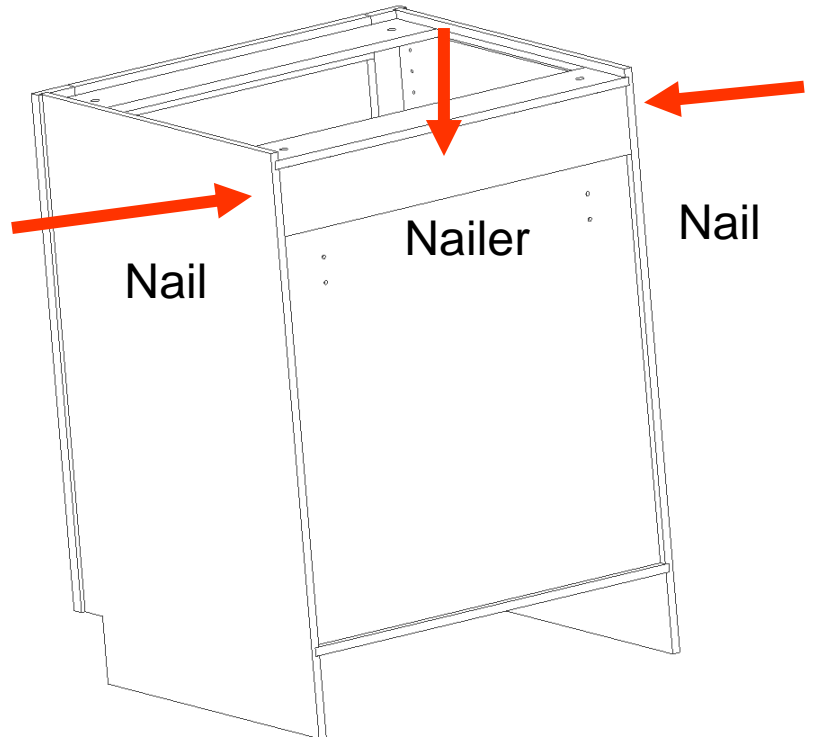

Attach rear mount sockets drawer slide brackets into pre-piloted holes on back of cabinet box.

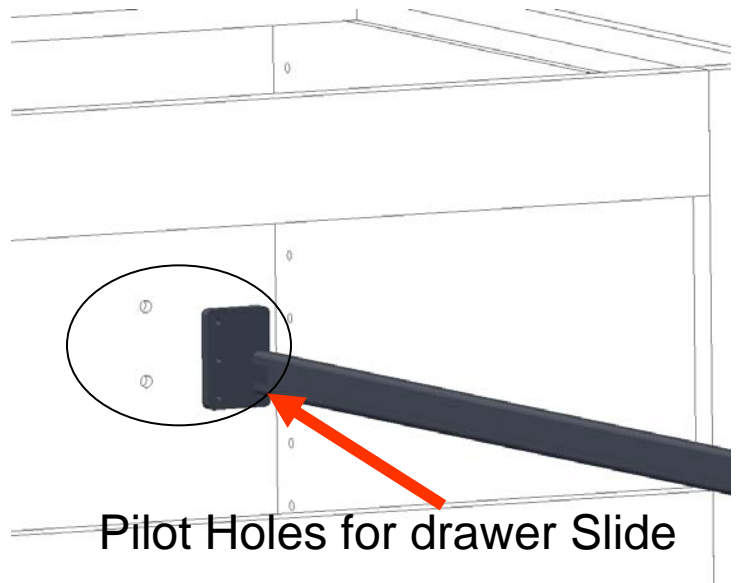

Front of drawer slide should be positioned 1/8" from front of face frame, and resting on horizontal drawer face frame. Fasten with screws into edge of face frame.

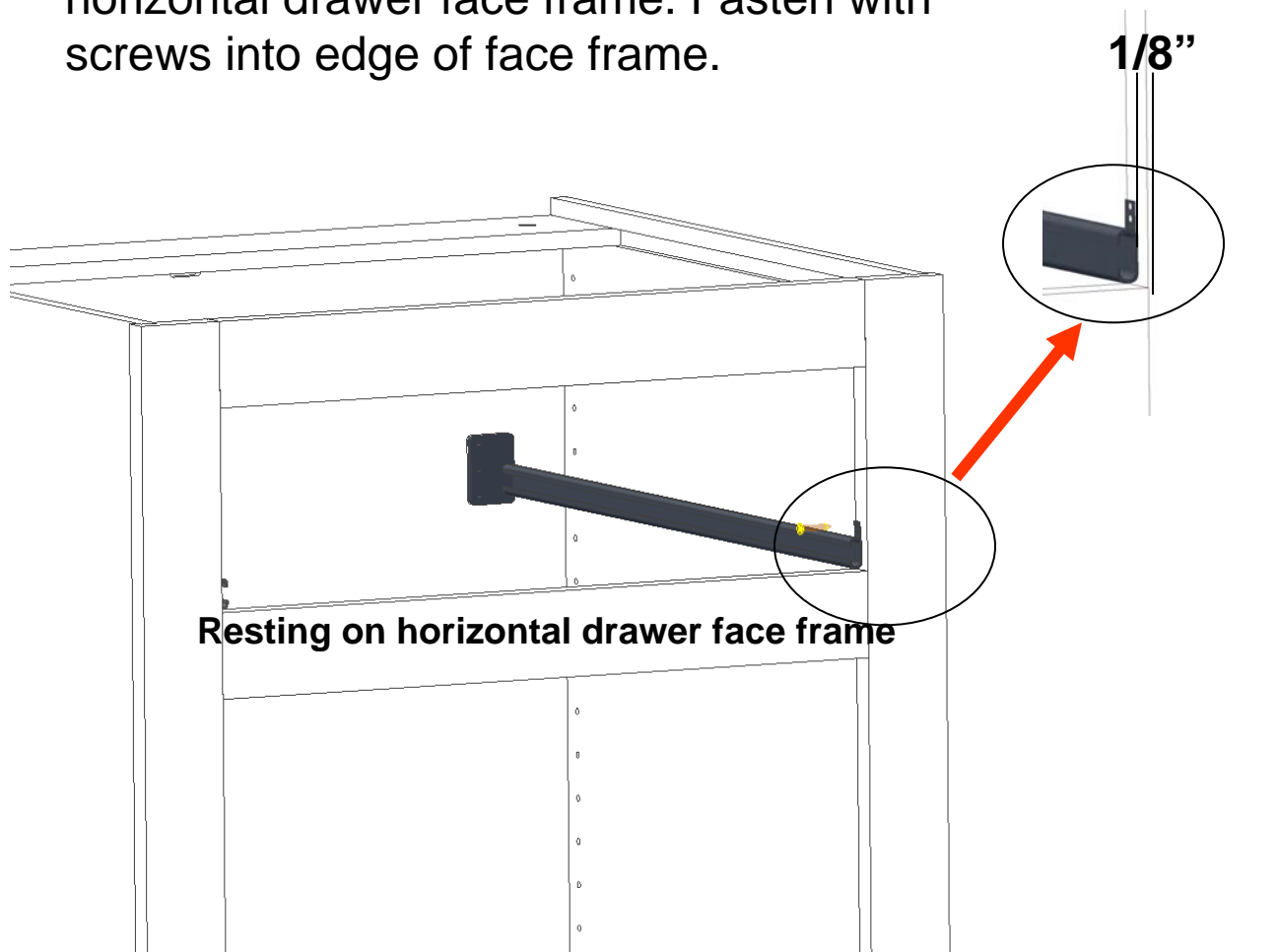

NAIL LOCATIONS FOR CABINET

