

Custom Wood Doors with Veneer Raised Center Panels



**Give your clients classic styling in a quality door
with an *Advantage*.**

What is this door's advantage? The unique value is the veneer center panel, which provides a more stable construction. Veneer panels won't shrink, swell, split or warp with humidity changes.

You'll also be impressed by the appearance. Only the highest grade logs are used to produce veneer. This results in panels with superior grain and color consistency. You're assured a uniform finish because we color match veneer panels to their hardwood frames. Choosing veneer also eliminates wood staves and defects common in hardwood panels.

Veneer panel doors are an ecologically responsible choice as well. They make efficient use of valuable hardwood resources.

Our custom wood doors are available in traditional raised or flat panel styles with accenting onlay and rope mouldings.

Doors are sold finished or raw. We offer six standard finish colors plus natural (clear coat). Custom colors are available. Order any quantity. You'll like our prices and the quick turnaround times will meet your installation schedule.



866.344.8132
www.northerncontours.com

Natural

Northern Contours Finishing Program

Spectrum Series



Quarter Sawn Maple



Rift Cut Red Oak



Quarter Sawn Cherry

5-piece Wood Doors with Veneer Center Panels



Plain Sliced Maple



Plain Sliced Red Oak



Plain Sliced Cherry



Plain Sliced Hickory



Quarter Sawn White Oak



Plain Sliced Alder



National Sales Office: 866.344.8132
www.northerncontours.com

Wood solids/veneers are unique products of nature and contain natural variations of grain and tone. These variations are part of the inherent charm and character of fine wood. Finished pieces may vary slightly from the images in texture, grain configuration, and color. Please refer to product samples before ordering.

Canoe Paddle (1400)

Northern Contours Finishing Program

Spectrum Series



Quarter Sawn Maple



Rift Cut Red Oak



Quarter Sawn Cherry

5-piece Wood Doors with Veneer Center Panels



Plain Sliced Maple



Plain Sliced Red Oak



Plain Sliced Cherry



Plain Sliced Hickory



Quarter Sawn White Oak



Plain Sliced Alder



National Sales Office: 866.344.8132
www.northerncontours.com

Wood solids/veneers are unique products of nature and contain natural variations of grain and tone. These variations are part of the inherent charm and character of fine wood. Finished pieces may vary slightly from the images in texture, grain configuration, and color. Please refer to product samples before ordering.

Log Cabin (1401)

Northern Contours Finishing Program

Spectrum Series



Quarter Sawn Maple



Rift Cut Red Oak



Quarter Sawn Cherry

5-piece Wood Doors with Veneer Center Panels



Plain Sliced Maple



Plain Sliced Red Oak



Plain Sliced Cherry



Plain Sliced Hickory



Quarter Sawn White Oak



Plain Sliced Alder



National Sales Office: 866.344.8132
www.northerncontours.com

Wood solids/veneers are unique products of nature and contain natural variations of grain and tone. These variations are part of the inherent charm and character of fine wood. Finished pieces may vary slightly from the images in texture, grain configuration, and color. Please refer to product samples before ordering.

Fox Tail (1402)

Northern Contours Finishing Program

Spectrum Series



Quarter Sawn Maple



Rift Cut Red Oak



Quarter Sawn Cherry

5-piece Wood Doors with Veneer Center Panels



Plain Sliced Maple



Plain Sliced Red Oak



Plain Sliced Cherry



Plain Sliced Hickory



Quarter Sawn White Oak



Plain Sliced Alder



National Sales Office: 866.344.8132
www.northerncontours.com

Wood solids/veneers are unique products of nature and contain natural variations of grain and tone. These variations are part of the inherent charm and character of fine wood. Finished pieces may vary slightly from the images in texture, grain configuration, and color. Please refer to product samples before ordering.

Pine Cone (1403)

Northern Contours Finishing Program

Spectrum Series



Quarter Sawn Maple



Rift Cut Red Oak



Quarter Sawn Cherry

5-piece Wood Doors with Veneer Center Panels



Plain Sliced Maple



Plain Sliced Red Oak



Plain Sliced Cherry



Plain Sliced Hickory



Quarter Sawn White Oak

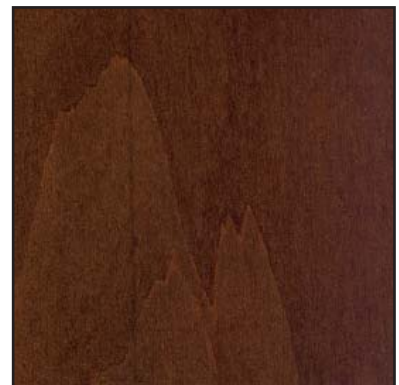

Plain Sliced Alder



National Sales Office: 866.344.8132
www.northerncontours.com

Wood solids/veneers are unique products of nature and contain natural variations of grain and tone. These variations are part of the inherent charm and character of fine wood. Finished pieces may vary slightly from the images in texture, grain configuration, and color. Please refer to product samples before ordering.

Moose Nose (1404)

Northern Contours Finishing Program

Spectrum Series

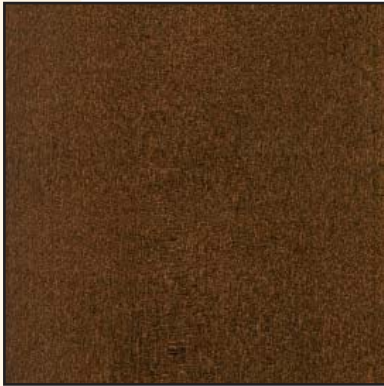

Quarter Sawn Maple



Rift Cut Red Oak



Quarter Sawn Cherry

5-piece Wood Doors with Veneer Center Panels

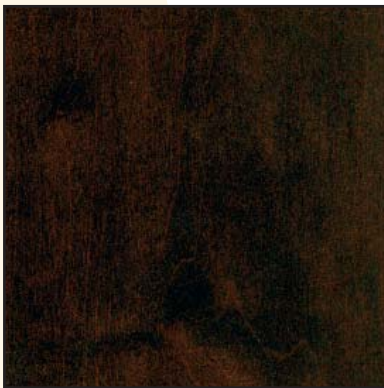

Plain Sliced Maple



Plain Sliced Red Oak

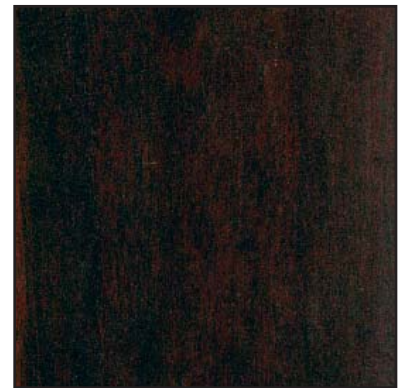

Plain Sliced Cherry



Plain Sliced Hickory



Quarter Sawn White Oak



Plain Sliced Alder



National Sales Office: 866.344.8132
www.northerncontours.com

Wood solids/veneers are unique products of nature and contain natural variations of grain and tone. These variations are part of the inherent charm and character of fine wood. Finished pieces may vary slightly from the images in texture, grain configuration, and color. Please refer to product samples before ordering.

Cordovan Leather (1405)

Northern Contours Finishing Program

Spectrum Series

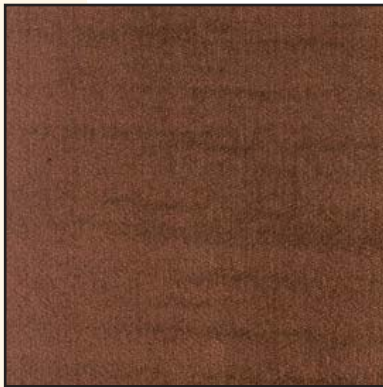

Quarter Sawn Maple



Rift Cut Red Oak



Quarter Sawn Cherry

5-piece Wood Doors with Veneer Center Panels



Plain Sliced Maple



Plain Sliced Red Oak

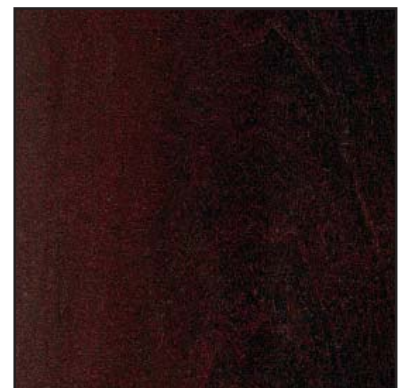

Plain Sliced Cherry



Plain Sliced Hickory



Quarter Sawn White Oak

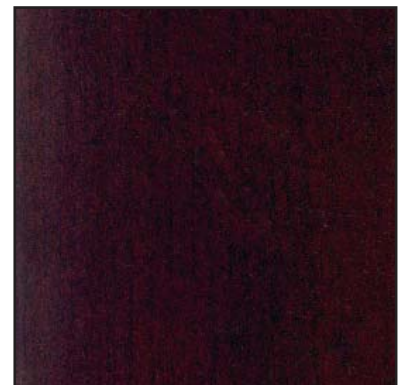

Plain Sliced Alder



National Sales Office: 866.344.8132
www.northerncontours.com

Wood solids/veneers are unique products of nature and contain natural variations of grain and tone. These variations are part of the inherent charm and character of fine wood. Finished pieces may vary slightly from the images in texture, grain configuration, and color. Please refer to product samples before ordering.



Custom Wood Doors with Veneer Center Panels

Manufactured in Vanceburg, KY

Mortise & Tenon Construction

Veneer Panel Doors

Raised Panel Door & Drawer Front Styles

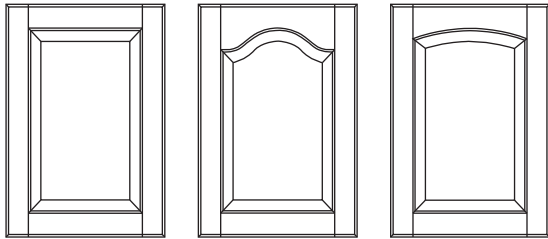

Square
2.25" (100)
3" (500)

Cathedral Arch
2.25" (101)

Roman Arch
2.25" (102)

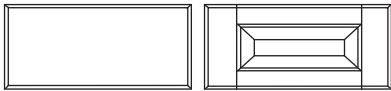

Slab Drawer
(105)

5-Pc Drawer
2.25" (106) 3" (506)

Flat Panel Door & Drawer Front Styles

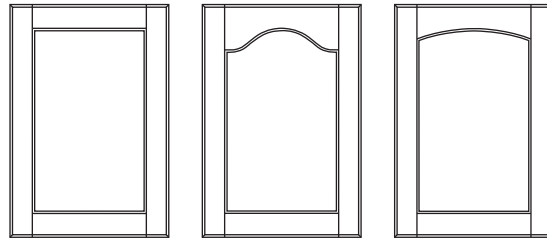

Square
2.25" (100)
3" (500)

Cathedral Arch
2.25" (101)

Roman Arch
2.25" (102)

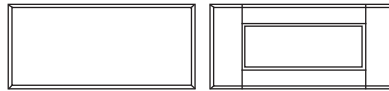

Slab Drawer
(105)

5-Pc Drawer
2.25" (106) 3" (506)

Outside Profiles

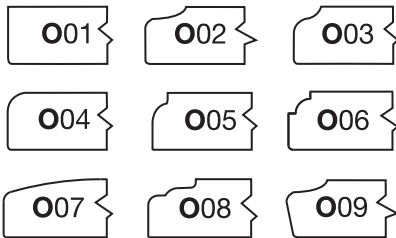

Reduced rail drawer front not available on O07.

Inside Profiles

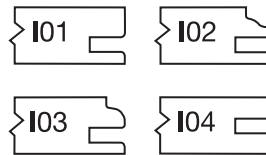

Note: Inside/Outside profile combinations are also available in Miter construction.

Panel Styles

Raised Panel Profiles

Veneer raised panels are .54" thick. P008 and P009 are only available on Square door styles. P008 is not available in paint grade MDF. P009 is only available in Cherry, Maple, and paint grade.

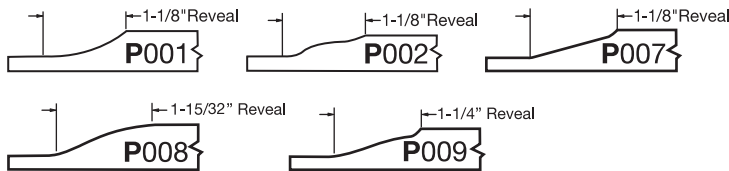

Flat Panel Profiles

P003 is .20" (5mm) thick, P010 is .415" thick, and P011 is .196" thick. P010 is only available with I04. P011 is only available in paint grade MDF.

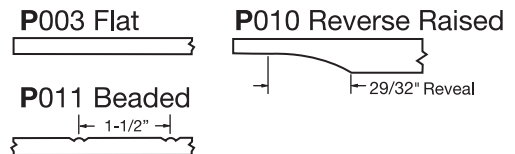

Frame & Mullion Styles

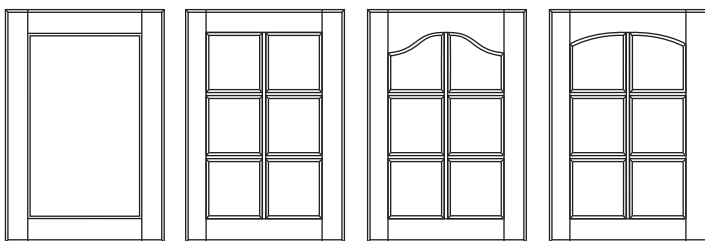

Square
Style (FR)

Square
Style (G06)

Cathedral Arch
(G06)

Roman Arch
(G06)

Frame & Mullion Profiles

Inside and outside profiles match door details. Grid details will be similar to inside profile.

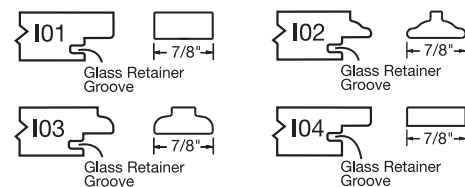

2-1/4" Stile & Rail Product Dimensions

	Door Size Minimum	Door Size Maximum*	Drawer Front Minimum	Frame Size Minimum	Frame / Mullion Size Maximum**
Square (100) with:					
Panel P003, P010, or P011	7-1/4" x 7-1/4"	31" x 96"	7-3/4" x 5-7/8"	7-3/4" x 6-1/4"	31" x 48"
Panel P001, P002, or P007	7-3/4" x 7-3/4"	31" x 96"	7-3/4" x 6-1/4"	7-3/4" x 7-3/4"	31" x 48"
Panel P008	8-7/16" x 8-7/16"	31" x 96"	8-7/16" x 6-15/16"	8-7/16" x 8-7/16"	31" x 48"
Panel P009	8" x 8"	31" x 96"	8" x 6-1/2"	8" x 8"	31" x 48"
Cathedral Arch (101) with:					
Panel P003, P010, or P011	9" x 9"	31" x 96"	-	9" x 9"	31" x 48"
Panel P001, P002, or P007	9" x 9"	31" x 96"	-	9" x 9"	31" x 48"
Roman Arch (102) with:					
Panel P003, P010, or P011	9" x 9"	31" x 96"	-	9" x 9"	31" x 48"
Panel P001, P002, or P007	9" x 9"	31" x 96"	-	9" x 9"	31" x 48"
Slab Drawer (105)	-	-	3" x 3"	-	-

Mullion Size Minimum 4 Opening: 11-3/8" x 11-3/8", 6 Opening: 11-3/8" x 15-1/4", 8 Opening: 11-3/8" x 19-1/8"

* Doors over 72" are not warranted against warpage.

** Contact customer service for information on frames and mullions over 48" in height.

3" Stile & Rail Product Dimensions

	Door Size Minimum	Door Size Maximum*	Drawer Front Minimum	Frame Size Minimum	Frame / Mullion Size Maximum**
Square (100) with:					
Panel P003, P010, or P011	8" x 8"	31" x 96"	8" x 6-1/2"	8" x 8"	31" x 48"
Panel P001, P002, or P007	8-1/2" x 8-1/2"	31" x 96"	8-1/2" x 7"	8-1/2" x 8-1/2"	31" x 48"
Panel P008	9-3/16" x 9-3/16"	31" x 96"	9-3/16" x 7-11/16"	9-3/16" x 9-3/16"	31" x 48"
Panel P009	8-3/4" x 8-3/4"	31" x 96"	8-3/4" x 7-1/4"	8-3/4" x 8-3/4"	31" x 48"
Slab Drawer (105)	-	-	3" x 3"	-	-

Mullion Size Minimum 4 Opening: 12-1/8" x 12-1/8", 6 Opening: 12-1/8" x 16", 8 Opening: 12-1/8" x 19-7/8"

* Doors over 72" are not warranted against warpage.

** Contact customer service for information on frames and mullions over 48" in height.

Notes

- Available in the following species: Alder, Cherry, Hickory, Maple, Red Oak, Quartered White Oak (3" only), Paint Grade with Maple panels and Paint Grade with MDF panels.
- Square door stiles and rails are available in 2-1/4" or 3" widths. Cathedral and Roman Arch door stiles and rails are available in 2-14" widths. Double Cathedral and Roman Arches are available.
- 5-piece drawer fronts have 2-1/4" stiles with 1-1/2" cross rails or 3" stiles with 1-1/2" cross rails. For full width rails on drawer fronts, order as a door and specify grain direction.
- Standard grain direction is vertical for doors, frames, and mullions; horizontal for drawer fronts.
- Pricing is per square foot. A 1-1/2 square foot minimum charge applies to each 5-piece component. Slab drawer fronts have no minimum square foot charge.
- We recommend that doors over 48" have a center rail. If ordered without a center rail there is no guarantee against warpage.
- Doors may be ordered below the minimum size and are produced with reduced stiles and/or rails. The narrowest stile is 1-1/2". Example: A 7" x 7" square door with a flat center panel will have 2-1/8" stiles and rails.

Mortise & Tenon Construction

Applied Moulding

Veneer Panel Doors

Door & Drawer Front Styles

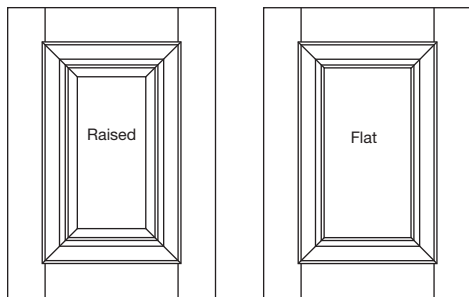

Square (400)

Square (400)



Slab Drawer (105)



Slab Drawer (105)

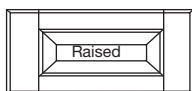

5-Pc Drawer (406)

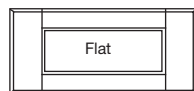

5-Pc Drawer (406)

Outside Profiles

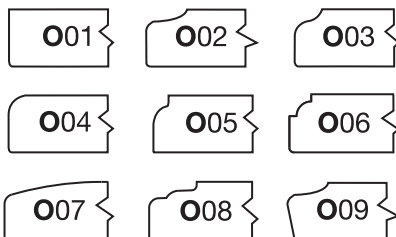

Reduced rail drawer front not available on O07.

Applied Moulding Drawer Profile

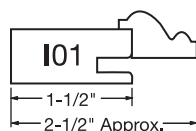

- Veneer raised panels are .54" thick
- Veneer flat panels are .20" (5mm) thick.

Panel Styles

Applied Moulding Panel Profiles

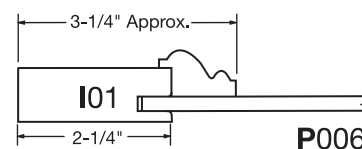
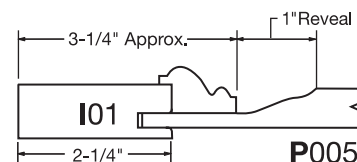
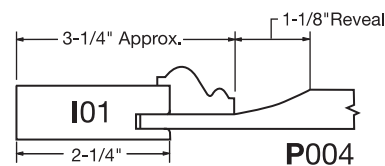

Frame & Mullion Styles

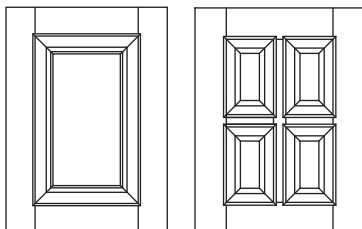

Applied Moulding Frame & Mullion Profiles

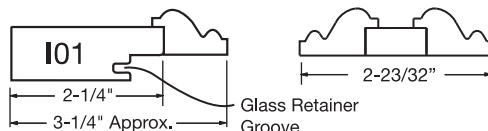

Dimensions & Notes

	Door Size Minimum	Door Size Maximum*	Drawer Front Minimum	Frame Size Minimum	Frame / Mullion Size Maximum**
Square (400) Flat Panel	8-1/2" x 8-1/2"	31" x 96"	-	8-1/2" x 8-1/2"	31" x 48"
Square (400) Raised Panel	9-3/4" x 9-3/4"	31" x 96"	-	9" x 9"	31" x 48"
5 Piece Drawer (406) Flat	-	-	6-1/2" x 6-1/2"	-	-
5 Piece Drawer (406) Raised	-	-	8-1/2" x 8-1/2"	-	-
Slab Drawer (105)	-	-	3" x 3"	-	-

Mullion Size Minimum 4 Opening: 15-1/8" x 15-1/8", 6 Opening: 15-1/8" x 21", 8 Opening: 15-1/8" x 26-7/8"

* Doors over 72" are not warranted against warpage.

** Contact customer service for information on frames and mullions over 48" in height.

- Available in the following species: Alder, Cherry, Maple, Red Oak, paint grade with Maple panels and Paint Grade with MDF panels.
- Pricing is per square foot. A 1-1/2 square foot minimum charge applies to each 5-piece component. Slab drawer fronts have no minimum square foot charge.
- Standard grain direction is vertical for doors, frames, and mullions; horizontal for drawer fronts.
- We recommend that doors over 48" have a center rail. If ordered without a center rail there is no guarantee against warpage.
- Doors may be ordered below the minimum size and are produced with reduced stiles and/or rails. The narrowest stile is 1-1/2". Example: An 8" x 8" square door with a flat center panel will have 2" stiles.

Door & Drawer Front Styles

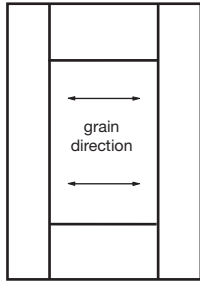

Square (600)

- 3" Stiles, 4" Rails.
- Horizontal grain direction is standard on panel.

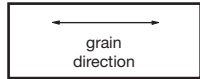

Slab Drawer (105)

- 3" Stiles
- Vertical grain direction on stiles; horizontal grain direction is standard on center piece.



3-Pc Drawer (601)

Outside Profile

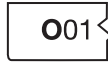

Panel Style

EuroShaker Panel Profile

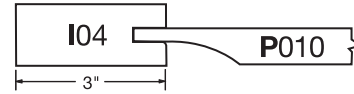

Frame Style

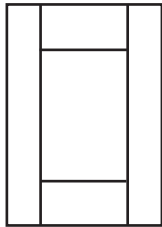

EuroShaker Frame Profile

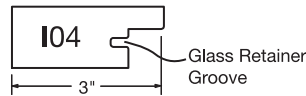

Mullions are not available

Dimensions & Notes

	Door Size Minimum	Door Size Maximum*	Drawer Front Minimum	Drawer Front Maximum	Frame Size Minimum	Frame Size Maximum**
Square (600) Flat Panel	9" x 11"	31" x 96"	-	-	9" x 11"	31" x 48"
3-Piece Drawer (601)	-	-	9" x 5"	36" x 14"	-	-
Slab Drawer (105)	-	-	3" x 3"	36" x 24"	-	-

* Doors over 72" are not warranted against warpage.

** Contact customer service for information on frames over 48" in height.

- Available in the following species (select grade only): Cherry, Maple, and Quartered White Oak.
- Pricing is per square foot. A 1-1/2 square foot minimum charge applies to each 5-Piece component. Slab drawer fronts have no minimum square foot charge.
- Standard grain direction: Horizontal for door panels, horizontal on drawer front center panels and vertical on drawer front stiles.
- We recommend that doors over 48" have a center rail. If ordered without a center rail there is no guarantee against warpage.

Mitered Construction Veneer Panel Doors

Door & Drawer Front Styles

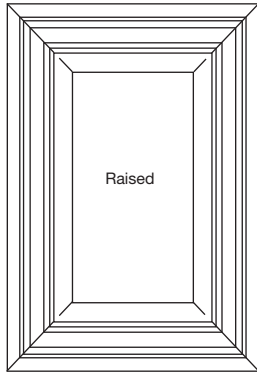

Mitered (200)

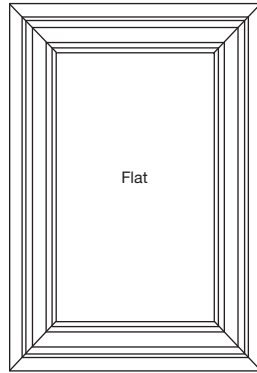

Mitered (200)

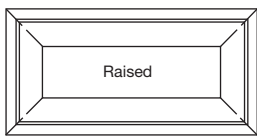

5-Pc Drawer (206)

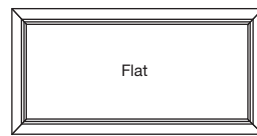

5-Pc Drawer (206)

Door Stile & Rail Profiles

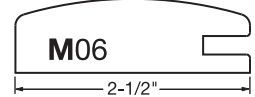
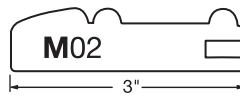
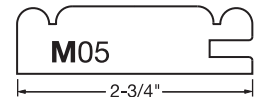
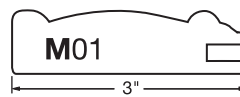

Note: Mortise and Tenon Inside/Outside profile combinations are also available in Miter construction.

Drawer Front Stile & Rail Profiles

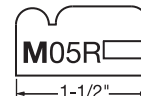
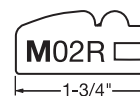

5 piece drawer fronts are not available on M06. If size allows, you can order as a door. Otherwise, we suggest ordering a slab drawer front with outside profile O07.

Panel Styles

Raised Panel Profiles

Veneer raised panels are .54" thick. P008 is not available in paint grade MDF. P009 is only available in Cherry, Maple, and paint grade.

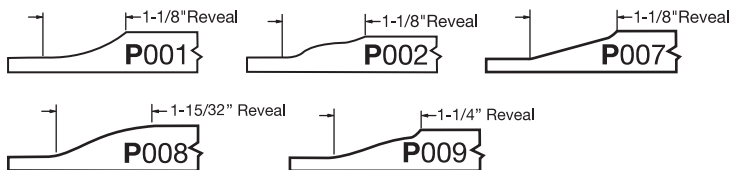

Flat Panel Profiles

P003 is .20" (5mm) thick. P011 is .196" thick. P011 is only available in paint grade MDF.

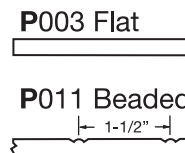

Frame & Mullion Styles

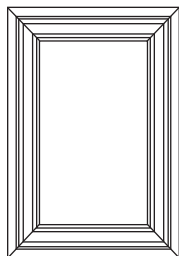

Mitered Frame Style (FR)

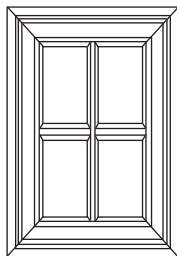

Mitered Mullion (G04)

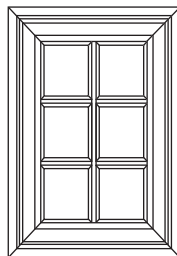

Mitered Mullion (G06)

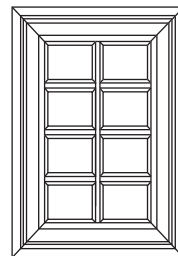

Mitered Mullion (G08)

Frame/Mullion Stile & Rail Profiles

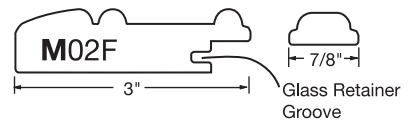
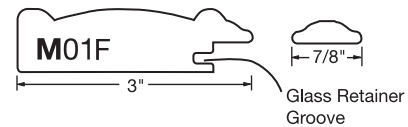

Mullions are not available for profiles M05 and M06

Dimensions & Notes

	Door Size Minimum	Door Size Maximum	Drawer Front Minimum	Frame Size Minimum	Frame / Mullion Size Maximum**
M01 or M02 with:			M01R or M02R		
Panel P003 or P011	9" x 9"	31" x 72"	6-1/2" x 6-1/2"	9" x 9"	31" x 48"
Panel P001, P002, or P007	9" x 9"	31" x 72"	6-1/2" x 6-1/2"	9" x 9"	31" x 48"
Panel P008	9-11/16" x 9-11/16"	31" x 72"	7-3/16" x 7-3/16"	9-11/16" x 9-11/16"	31" x 48"
Panel P009	9-1/4" x 9-1/4"	31" x 72"	6-3/4" x 6-3/4"	9-1/4" x 9-1/4"	31" x 48"
M05 with:			M05R		
Panel P003 or P011	8-3/4" x 8-3/4"	31" x 72"	6-1/4" x 6-1/4"	8-3/4" x 8-3/4"	31" x 48"
Panel P001, P002, or P007	8-3/4" x 8-3/4"	31" x 72"	6-1/4" x 6-1/4"	8-3/4" x 8-3/4"	31" x 48"
Panel P008	9-7/16" x 9-7/16"	31" x 72"	7-3/16" x 7-3/16"	9-7/16" x 9-7/16"	31" x 48"
Panel P009	9" x 9"	31" x 72"	6-3/4" x 6-3/4"	9" x 9"	31" x 48"
M06 with:			Slab O07		
Panel P003 or P011	8-1/4" x 8-1/4"	31" x 72"	3" x 3"	8-1/4" x 8-1/4"	31" x 48"
Panel P001, P002, or P007	8-1/4" x 8-1/4"	31" x 72"	3" x 3"	8-1/4" x 8-1/4"	31" x 48"
Panel P008	8-15/16" x 8-15/16"	31" x 72"	3" x 3"	8-15/16" x 8-15/16"	31" x 48"
Panel P009	8-1/2" x 8-1/2"	31" x 72"	3" x 3"	8-1/2" x 8-1/2"	31" x 48"

Mullion Size Minimum 4 Opening: 12-7/8" x 12-7/8", 6 Opening: 12-7/8" x 17", 8 Opening: 12-7/8" x 20-5/8"

** Contact customer service for information on frames and mullions over 48" in height.

- Available in the following species: Alder, Cherry, Maple, Red Oak, paint grade with Maple panels and paint grade with MDF panels.
- Pricing is per square foot. A 1-1/2 square foot minimum charge applies to each 5-piece component. Slab drawer fronts have no minimum square foot charge.
- Standard grain direction is vertical for doors, frames, and mullions; horizontal for drawer fronts.
- Mitered doors do not have a center cross rail. Doors over 60" will not be warranted against warpage.

Mitered Construction Applied Rope Moulding Veneer Panel Doors

Door & Drawer Front Styles

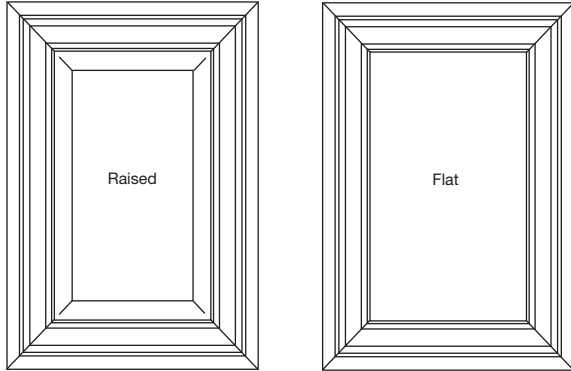

Mitered (300)

Mitered (300)

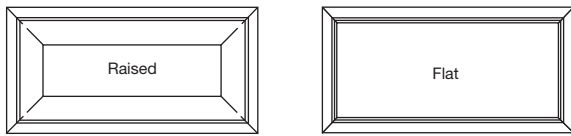

5-Pc Drawer (306)

5-Pc Drawer (306)

Door Stile & Rail Profiles

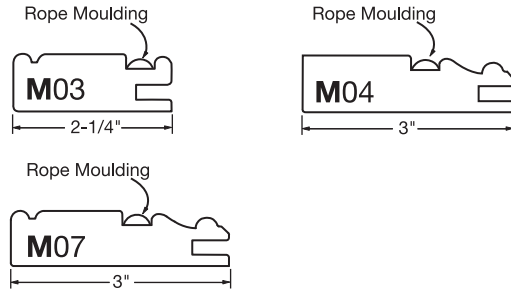

Drawer Front Stile & Rail Profiles

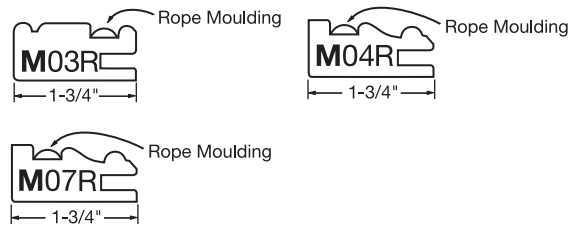

Panel Styles

Raised Panel Profiles

Veneer raised panels are .54" thick. P008 is not available in paint grade MDF. P009 is only available in Cherry, Maple, and paint grade.

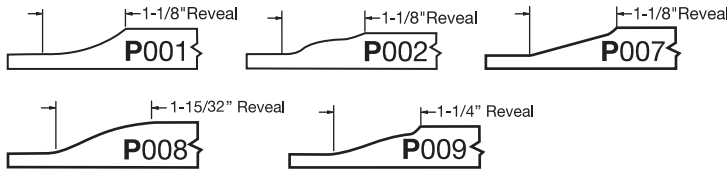

Flat Panel Profiles

P003 is .20" (5mm) thick. P011 is .196" thick. P011 is only available in paint grade MDF.

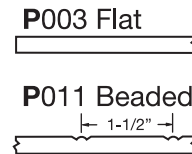

Frame & Mullion Styles

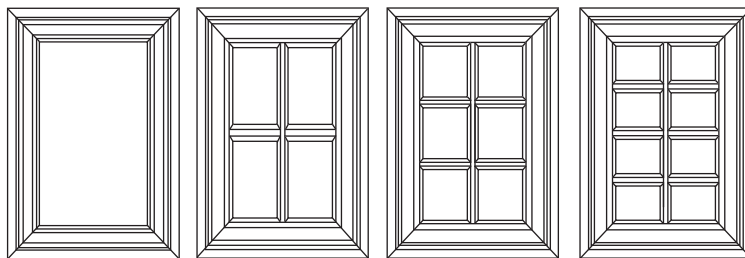

Mitered Frame Style (FR)

Mitered Mullion (G04)

Mitered Mullion (G06)

Mitered Mullion (G08)

Frame/Mullion Stile & Rail Profiles

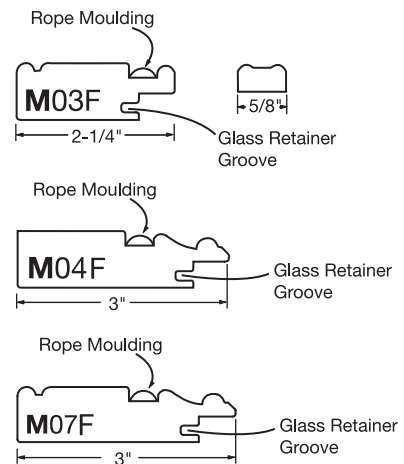

Mullions are not available for profiles M04 and M07

Dimensions & Notes

	Door Size Minimum	Door Size Maximum	Drawer Front Minimum	Frame Size Minimum	Frame / Mullion Size Maximum**
M03 with:			M03R		
Panel P003 or P011	7-3/4" x 7-3/4"	31" x 72"	6-1/2" x 6-1/2"	7-3/4" x 7-3/4"	31" x 48"
Panel P001, P002, or P007	7-3/4" x 7-3/4"	31" x 72"	6-1/2" x 6-1/2"	7-3/4" x 7-3/4"	31" x 48"
Panel P008	8-7/16" x 8-7/16"	31" x 72"	7-3/16" x 7-3/16"	8-7/16" x 8-7/16"	31" x 48"
Panel P009	8" x 8"	31" x 72"	6-3/4" x 6-3/4"	8" x 8"	31" x 48"
M04 or M07 with:			M04R or M07R		
Panel P003 or P011	9" x 9"	31" x 72"	6-1/2" x 6-1/2"	9" x 9"	31" x 48"
Panel P001, P002, or P007	9" x 9"	31" x 72"	6-1/2" x 6-1/2"	9" x 9"	31" x 48"
Panel P008	9-11/16" x 9-11/16"	31" x 72"	7-3/16" x 7-3/16"	9-11/16" x 9-11/16"	31" x 48"
Panel P009	9-1/4" x 9-1/4"	31" x 72"	6-3/4" x 6-3/4"	9-1/4" x 9-1/4"	31" x 48"

Mullion Size Minimum 4 Opening: 11-3/8" x 11-3/8", 6 Opening: 11-3/8" x 15-1/4", 8 Opening: 11-3/8" x 19-1/8"

** Contact customer service for information on frames and mullions over 48" in height.

- Available in the following species: Alder, Cherry, Maple, Red Oak, Paint Grade Maple and Paint Grade with MDF panels.
- Pricing is per square foot. A 1-1/2 square foot minimum charge applies to each 5-piece component. Slab drawer fronts have no minimum square foot charge.
- Standard grain direction is vertical for doors, frames, and mullions; horizontal for drawer fronts.
- Mitered doors do not have a center cross rail. Doors over 60" will not be warranted against warpage.

Options

Hinge Boring

HB 1

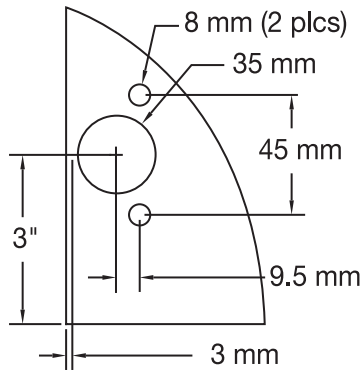

35 mm diameter bore and two 8 mm diameter holes for dowels, 1/2" (12.7 mm) deep

HB 2

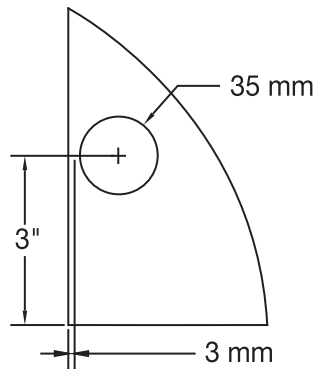

Single 35 mm diameter hole, 1/2" (12.7 mm) deep

Standard hole placement and number of holes are shown to the right. If you wish to specify different hole locations, please supply a drawing with your order.

Heights
6-15/16" to 12"

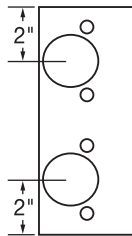

Heights over
12" to 42"

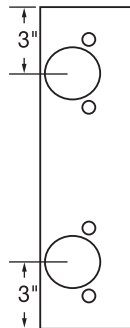

Heights over
42" to 72"

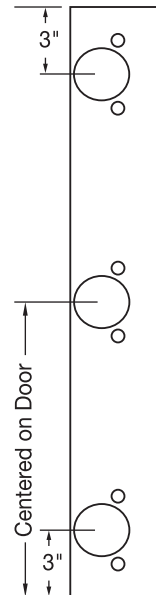

Heights over
72" to 96"



Lazy Susan Doors

45° Miter Lazy Susan (Mortise & Tenon doors only)

When ordering a 45° Miter Lazy Susan, we recommend ordering each door with one stile 3/4" oversized (ex: 3" stile for standard 2-1/4" stile width) to keep the stile width on the face constant after 45° miter is applied. For arched doors, indicate which is left and which is right. One stile on each door will receive a square edge (Outside Detail O01.) **Customers are responsible for specifying changes in dimension and cutting 45° bevel on stiles.**

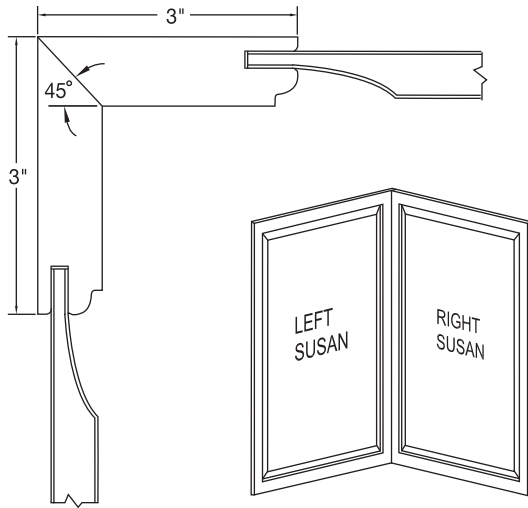

Butt Joint Lazy Susan (Mortise & Tenon doors only)

Each Butt Joint Lazy Susan has a wider stile on one side of the door to keep the stile width constant on the face. (If the standard stile width is 2-1/4", you would need one stile to be 3".) For arched doors, indicate which is left and which is right. One stile on each door will receive a square edge (Outside Detail O01.) **Customers are responsible for specifying changes in dimension.**

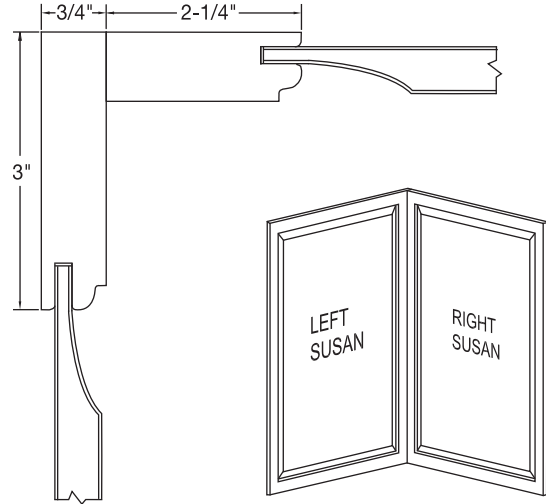

Appliance Panels

AP 1

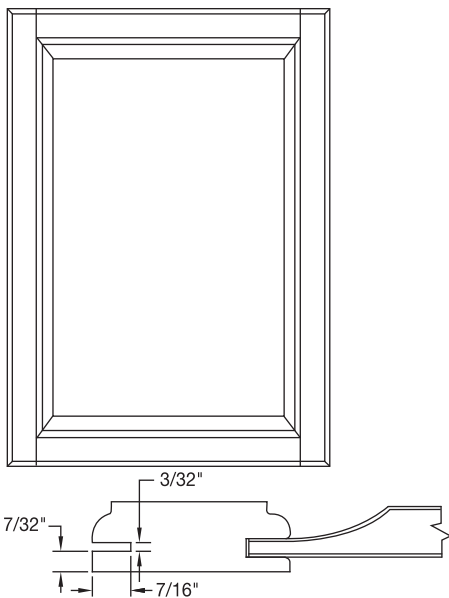

The appliance slot is routed around all four sides. It is available on all mortise & tenon and miter doors. Standard routing as shown. If these dimensions are not appropriate for your appliances, please send a detailed drawing to customer service.

AP 2

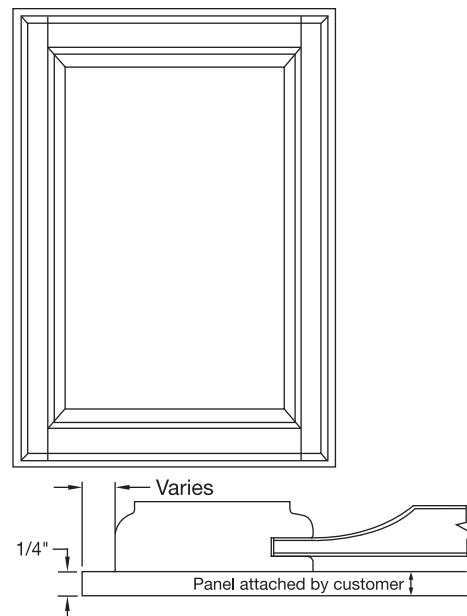

The 1/4" attachment panel is attached by the customer. It may be ordered cut to size. Call for pricing. Information is for this panel only. The proper door must also be ordered.

Contact customer service or your sales representative for additional pricing and ordering information.

Options

Wainscot Panels

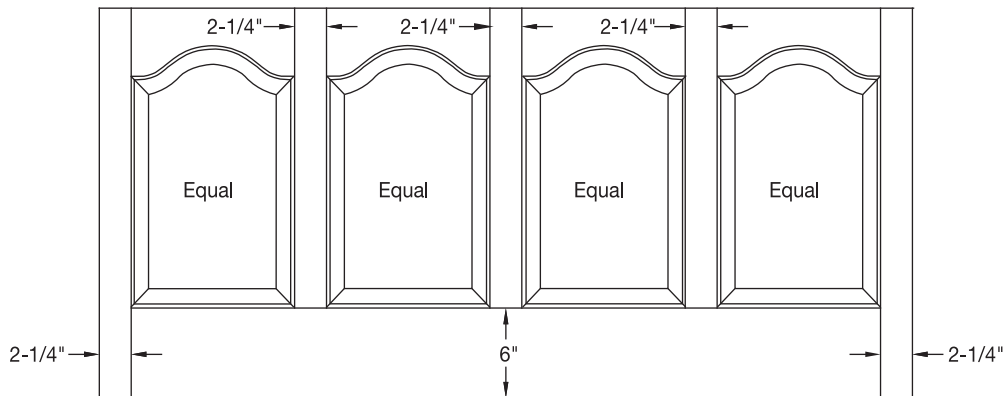

Dimensions shown are standard. Optional dimensions are available. Pricing for wainscots will vary based on complexity. For a quote, fax a detailed drawing to customer service.

Fingerpulls

The standard placement for fingerpulls on doors is top and bottom and on drawer fronts is top or bottom. The standard fingerpull is 4" long and centered with a 1/4" thickness and depth. All fingerpulls are machined according to the following drawings. Fingerpulls are available for all door and drawer front styles excluding O09.

Side View

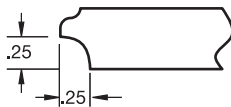

Edge View

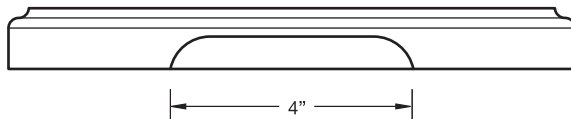

Warranty

Northern Contours warrants all doors, drawer fronts and accessory items (unless otherwise noted) against de-lamination, warping, twist, swelling and other manufacturing defects for the period of one year after the date of sale. This warranty assumes the following:

- Proper care and handling must be exercised. Abusive handling of products is not covered.
- We cannot warrant against abnormal heat, humidity, dryness or cold.
- Poor or improper finishing done by others is not covered.
- Warranty covers the repair or replacement of the product only and our liability under this warranty will not exceed the invoiced amount of the products.
- Natural variation in the color, texture or grain of the wood is not considered a defect and is not replaceable under this warranty.

Complete warranty information is available from our customer service department.

Material Grade Specifications

Select - All Species: uniform color and grain, little to no mineral streaks, only small inconspicuous burl and pin knots are allowed.

Natural Cherry: random color, sap, gum pockets, mineral and small knots allowed.

Natural Maple: random color, sugar, mineral, heartwood and small knots allowed.

Natural Red Oak: random color, mineral stain and small knots allowed.

Paint Grade: random color, mineral, sapwood, burl and large sound knots allowed. Panel is paint grade Maple or MDF; frames are Maple.

Finishing

Finishing options include: Canoe Paddle-1400, Log Cabin-1401, Fox Tail-1402, Pine Cone-1403, Moose Nose-1404, Cordovan Leather-1405, and Natural (clear coat). Refer to color pages at the beginning of catalog and/or stain samples. Most stains are water based and UV finished to a sheen of 35-40. Leadtime is 15 days. Custom colors available for a custom match fee to be paid whether or not order is placed. Maximum of 2 attempts will be made to meet approval.

Standard Product Specifications

The following standard specifications apply unless otherwise noted:

Door thickness = 3/4"

Door stile and rail widths:

Mortise & Tenon stiles and rails = 2-1/4" or 3"

Mitered vary by style, see drawings

Drawer front stile and rail widths:

Mortise & Tenon stiles = 2-1/4" or 3", rails = 1-1/2"

Mitered vary by style, see drawings

Flat panel thickness = 5 mm

Raised panel thickness = 1/2", .54" with veneer

Please note: Many of our products can be customized to meet your requirements. Contact customer service for information and additional specifications as needed.

Finished Dimension Tolerance

The outside dimensions of all doors and drawer fronts will have a tolerance of +/- 1/32" or 1 mm.

Warpage Tolerance

Mortise and tenon doors less than 48" will have a 1/8" warpage tolerance. Mortise and tenon doors over 48" but less than 72" will have a 1/4" warpage tolerance, provided they are ordered with a center rail. Mortise and tenon doors over 72" will not be warranted against warp.

Mitered doors less than 48" will have a 1/8" warpage tolerance. Mitered doors over 48" but less than 60" will have a 3/16" warpage tolerance. Mitered doors over 60" will not be warranted against warp.

Special Center Rail Placement

We recommend that any Mortise & Tenon door over 48" in height be ordered with a center rail. Doors over 48" tall without a center rail will not be warranted for warpage. Please note: doors over 48" will not automatically be manufactured with a center rail; it must be specified by the customer. If ordered, the center rail will be placed in the middle of the door. You may specify where you want the center rail for an upcharge. This requires a drawing showing the distance from the top of the door to the top of the center rail. See price list for fees on standard and special placement center rails.

Placing an Order

Samples

Northern Contours offers discounted product samples for sample racks, showroom displays and display kitchens. Contact your sales representative for details.

Quotes

Quotes are available prior to placing your order. To receive a quote, check the "quote" box on the order form and our customer service department will contact you. You may also contact customer service directly at 606-796-0322 or fax 606-796-0379 to request pricing. Quotes are valid for 30 days unless otherwise noted.

Ordering Instructions

Orders may be placed 7 days a week, 24 hours a day by fax. You may also send them via U.S. mail. Orders received after 2:00 pm Eastern time will be processed the following business day. Send orders to:

Northern Contours
742 W KY 8
Vanceburg, KY 41179
Phone: 606.796.0322
Fax: 606.796.0379

Orders may be placed in inches or millimeters. Order exact sizes to the nearest 1/32" or nearest millimeter. Always order width x height. All pricing is per square foot and calculated to the nearest hundredth of a square foot for standard products. There is a 1-1/2 square foot minimum charge on each 5-piece component. Custom components are available; please call for a quote.

To ensure that we manufacture exactly what you require, please use the Northern Contours Custom Wood Door order form and follow these steps:

1. Check "order" box at the top of the page.
2. Fill out Date, Job Name, Customer ID, Ordered By, and PO#.
3. Fill out the Bill To and Ship To information.
4. Check box for desired Material/Specie.
5. Check boxes for Door Style and Drawer Style (Refer to Product Guide for details).
6. Check boxes for desired door Construction and Drawer Grain Direction (horizontal is standard).
7. Check boxes for desired profiles. For Mortise and Tenon construction, choose Outside **and** Inside profile details. For Mitered construction, choose Outside **and** Inside profile **OR** a Mitered Stile & Rail profile option.
8. Check box for Panel Profile.
9. Check box for Finishing Option. If no option is selected, items will be shipped raw.
10. Enter Quantity, Type, Width, Height and any Special Instructions (O02 one long side, drawer front full rail or reduced rails, etc.) When ordering frames enter FR in "type". When ordering mullions enter G04, G06, G08, etc. (G04 is a 4 opening mullion.)
11. Check Hinge Boring option if needed. Attach drawing if custom.
12. Check color for Rubber Glass Retainers if needed (available in clear, brown, white or black).
13. Check Preferred Shipping Method and Receiving Capabilities.
14. Check Payment Method.
15. For special requirements, use drawing area or attach drawings.
16. Sign and send.

New Accounts

All new accounts require a minimum deposit of 50% down by credit card, check or cash. The balance will be invoiced at 1% 10, net 30. Initial orders for new accounts will not be put into production until the deposit has been received.

Order Acknowledgement

Northern Contours acknowledges all orders, usually within 24 hours. If you do not receive an acknowledgement please contact customer service to be sure that we have received your order.

When you receive your order acknowledgement, review it carefully to be sure it matches your requirements. Northern Contours is not responsible for unreported discrepancies. Note: all orders go into production the morning of the next business day.

Order Changes and Cancellations

Any change or cancellation made to your order after it has gone into production is subject to a change fee plus the cost of time and materials. Changes or cancellations must be received in writing. All changes and cancellations will be acknowledged. Changes and cancellations are not allowed on rush orders due to the immediacy of production.

Lead Time

Standard lead time is **5 to 7 working days** for unfinished product depending on the complexity of the product ordered. Standard lead time for finished product is **15 working days**. Lead times may change so please ask for the current lead time when you place your order.

Rush Orders

Rush service is available for an **upcharge of 20%** over regular pricing with a \$10 minimum. Rush orders are defined as **shipping in 4 working days** for most unfinished products and **7 working days** for most finished products. Lead times may change so please ask for current lead time when you place your order.

Packaging Charge

Product is shipped according to size and quantity. All of our packaging specifications exceed common carrier standards. Standard packaging charges are listed on our price pages. This charge will be added to your invoice and does not include freight charges.

Shipping

All prices are FOB Vanceburg, Kentucky. Order size and delivery location will determine how your product will be shipped. Typically, smaller orders ship via FedEx and larger orders ship via common carrier. Arrangements can be made for orders to be picked up. Please indicate your shipping preference and receiving capabilities (shipping dock, forklift or pallet jack) on your Northern Contours order form.

FedEx charges are based on the total weight of the order and are added to the invoice at the time of shipment. Oversized items are subject to additional shipping charges. Common carrier orders are shipped prepaid and freight is invoiced.

Order Receipt

Northern Contours strives to ship your orders accurately, completely and on time. All orders are shipped FOB manufacturing facility. Northern Contours is not responsible for any product damaged in transit or damaged due to excessive handling or poor storage conditions. Please inspect the contents of your shipment before signing your delivery receipt.

Freight Damage

If your order was **shipped via FedEx** and is damaged, sign for it and immediately contact Northern Contours to report the issue.

If your order was **shipped common carrier**, you must sign the delivery receipt in one of the following ways:

1. Sign noting that there is damage.
2. Sign noting that you suspect that there is possibly concealed damage.
3. If you do not have time to inspect your product when it arrives, note on delivery receipt that you did not inspect it. You will then need to inspect it within 24 hours and notify Northern Contours of any damage.
4. Simply sign your name. This indicates you've inspected the order and accept responsibility for the condition of its contents.

You must keep a copy of the delivery receipt.

If you sign your delivery receipt without any notes, Northern Contours will charge you for remakes. **Please call Northern Contours within 24 hours of receipt of any freight damaged product.**

Order Discrepancy

Please inspect your entire order to ensure the condition of your product is acceptable and quantity and sizes agree with your order acknowledgement. If there are any discrepancies or quality concerns, let us know within 10 working days of receipt. Northern Contours is not responsible for missing or damaged items unless reported within this time.

Placing an Order

Remakes

In the event that you receive a component with a defect as a result of a Northern Contours error, please provide detailed information regarding the reason for the remake so that we can be sure to manufacture the remake correctly. We will ship a replacement at no charge, freight prepaid via regular shipping, within 2 working days for most products.

If we are not responsible, we will ship a remake at regular price and shipping in the standard lead time. If you require faster service, see the **Rush Orders** section and contact customer service.

Northern Contours may request that faulty product be returned for inspection. This allows us to examine the components in order to understand the source of the flaw and work to improve product quality.